

PART -1
One-Mark Question
MATHEMATICS

1. Suppose a, b, c are three distinct real numbers. Let $P(x) = \frac{(x-b)(x-c)}{(a-b)(a-c)} + \frac{(x-c)(x-a)}{(b-c)(b-a)} + \frac{(x-a)(x-b)}{(c-a)(c-b)}$.

When simplified, $P(x)$ becomes

- (A) 1 (B) x
(C) $\frac{x^2 + (a+b+c)(ab+bc+ca)}{(a-b)(b-c)(c-a)}$ (D) 0

Ans. (A)

Sol.
$$P(x) = \frac{(x-b)(x-c)}{(a-b)(a-c)} + \frac{(x-c)(x-a)}{(b-c)(b-a)} + \frac{(x-a)(x-b)}{(c-a)(c-b)}$$

Let $P(a) = 1 + 0 + 0 = 1$

$P(b) = 0 + 1 + 0 = 1$

$P(c) = 0 + 0 + 1 = 1$

$\therefore P(x) = 1$ for all $x \in \mathbb{R}$.

2. Let a, b, x, y be real numbers such that $a^2 + b^2 = 81$, $x^2 + y^2 = 121$ and $ax + by = 99$. Then the set of all possible values of $ay - bx$ is -

- (A) $\left[0, \frac{9}{11}\right]$ (B) $\left(0, \frac{9}{11}\right)$ (C) $\{0\}$ (D) $\left[\frac{9}{11}, \infty\right)$

Ans. (C)

Sol. $a^2 + b^2 = 81$

$x^2 + y^2 = 121$

$ax + by = 99$

$(a^2 + b^2)(x^2 + y^2) = (81)(121) \dots(1)$

and $(ax + by)^2 = (99)^2 \dots(2)$

$(1) - (2)$

$(ay - bx)^2 = 0$

$ay - bx = 0$

3. If $x + \frac{1}{x} = a$, $x^2 + \frac{1}{x^3} = b$, then $x^3 + \frac{1}{x^2}$ is -

(A) $a^3 + a^2 - 3a - 2 - b$

(B) $a^3 - a^2 - 3a + 4 - b$

(C) $a^3 - a^2 + 3a - 6 - b$

(D) $a^3 + a^2 + 3a - 16 - b$



Ans. (A)

Sol. $x + \frac{1}{x} = a$ and $x^2 + \frac{1}{x^3} = b$

$$\left(x + \frac{1}{x}\right)^2 = a^2 \Rightarrow x^2 + \frac{1}{x^2} + 2 = a^2 \quad \dots(1)$$

and $\left(x + \frac{1}{x}\right)^3 = a^3 \Rightarrow x^3 + \frac{1}{x^3} + 3x \cdot \frac{1}{x} \left(x + \frac{1}{x}\right) = a^3 \quad \dots(2)$

adding (1) & (2)

$$\left(x^2 + \frac{1}{x^2}\right) + \left(x^3 + \frac{1}{x^3}\right) + 2 + 3\left(x + \frac{1}{x}\right) = a^2 + a^3$$

$$b + \left(x^3 + \frac{1}{x^2}\right) + 2 + 3a = a^2 + a^3$$

$$\therefore x^3 + \frac{1}{x^2} = a^3 + a^2 - 3a - 2 - b$$

4. Let a, b, c, d be real numbers such that $|a - b| = 2$, $|b - c| = 3$, $|c - d| = 4$. Then the sum of all possible values of $|a - d|$ is

(A) 9

(B) 18

(C) 24

(D) 30

Ans. (B)

Sol. $|a - b| = 2 \Rightarrow a - b = \pm 2$

$$|a - c| = 3 \Rightarrow b - c = \pm 3$$

$$|c - d| = 4 \Rightarrow c - d = \pm 4$$

Possible values of $a - d$ are $\pm 9, \pm 5, \pm 3, \pm 1$

$$|a - d| = 9, 5, 3, 1$$

Sum = 18.

5. Below are four equations in x. Assume that $0 < r < 4$. Which of the following has the largest solution for x ?

(A) $5\left(1 + \frac{r}{\pi}\right)^x = 9$

(B) $5\left(1 + \frac{r}{17}\right)^x = 9$

(C) $5(1 + 2r)^x = 9$

(D) $5\left(1 + \frac{1}{r}\right)^x = 9$

Ans. (B)

Sol. Given $0 < r < 4$
in the given options

$$(\text{Base})^x = \frac{9}{5}$$

for largest value of x, base should be minimum.

\therefore in option B base $\left(1 + \frac{r}{17}\right)$ is minimum for $0 < r < 4$.

6. Let ABC be a triangle with $\angle B = 90^\circ$. Let AD be the bisector of $\angle A$ with D on BC. Suppose $AC = 6$ cm and the area of the triangle ADC is 10 cm^2 . Then the length of BD in cm is equal to

- (A) $\frac{3}{5}$ (B) $\frac{3}{10}$ (C) $\frac{5}{3}$ (D) $\frac{10}{3}$

Ans. (D)

Sol.

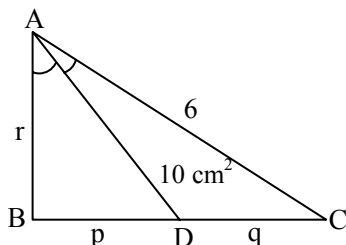

From angle bisector theorem

$$\frac{r}{6} = \frac{p}{q}$$

$$q r = 6 p \quad \dots(1)$$

$$\text{Area of } \triangle ADC = 10 \text{ cm}^2$$

$$\frac{1}{2} (\text{DC}) (\text{AB}) = 10$$

$$\frac{1}{2} (q) (r) = 10$$

$$q r = 20$$

From (1)

$$\Rightarrow 20 = 6 p$$

$$p = \frac{20}{6} = \frac{10}{3}$$

7. A piece of paper in the shape of a sector of a circle (see Fig. 1) is rolled up to form a right-circular cone (see Fig. 2). The value of the angle θ is.

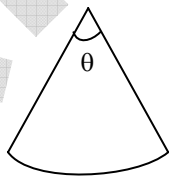

Fig.1

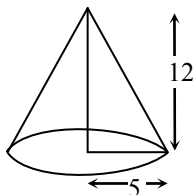
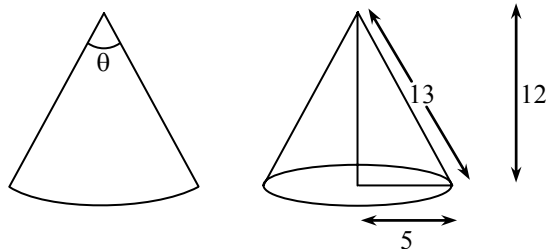

Fig.2

- (A) $\frac{10\pi}{13}$ (B) $\frac{9\pi}{13}$ (C) $\frac{5\pi}{13}$ (D) $\frac{6\pi}{13}$

Ans. (B)

Sol.



Slant height = 13

$$\theta = \frac{S}{r}$$

$$\Rightarrow S = r \theta$$

$$\Rightarrow 2\pi(5) = 13 \theta$$

$$\Rightarrow \theta = \frac{10\pi}{13}$$

8. In the adjoining figure $AB = 12$ cm, $CD = 8$ cm, $BD = 20$ cm; $\angle ABD = \angle AEC = \angle EDC = 90^\circ$. If $BE = x$, then

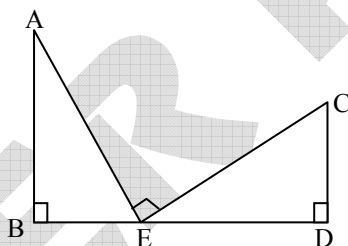

- (A) x has two possible values whose difference is 4
- (B) x has two possible values whose sum is 28
- (C) x has only one value and $x \geq 12$
- (D) x cannot be determined with the given information

Ans. (A)

Sol.

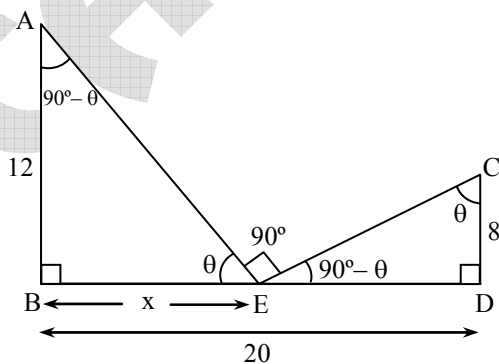

$$\frac{12}{x} = \frac{20-x}{8} \Rightarrow x^2 - 20x + 96 = 0$$

$$\Rightarrow x = 8, 12$$

9. Three circles each of radius 1, touch one another externally and they lie between two parallel lines. The minimum possible distance between the lines is

(A) $2 + \sqrt{3}$

(B) $3 + \sqrt{3}$

(C) 4

(D) $2 + \frac{1}{\sqrt{3}}$

Ans. (A)

Sol.

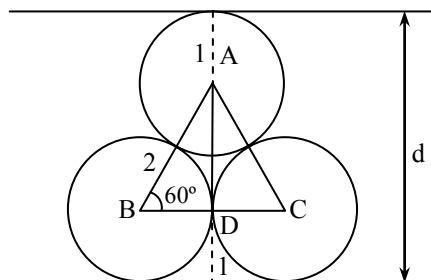

$$\sin 60^\circ = \frac{AD}{2}$$

$$AD = 2 \sin 60^\circ = \frac{2\sqrt{3}}{2} = \sqrt{3}$$

$$d = 1 + AD + 1$$

$$d = 2 + \sqrt{3}$$

10. The number of distinct prime divisors of the number $512^3 - 253^3 - 259^3$ is

(A) 4

(B) 5

(C) 6

(D) 7

Ans. (C)

Sol.

$$\begin{aligned} & (512)^3 - 253^3 - 259^3 \\ &= (512)^3 - [(253^3) + (259^3)] \\ &= (512)^3 - (253 + 259)(253^2 + 259^2 - (253)(259)) \\ &= (512)^3 - (512)[(253 + 259)^2 - 2(253)(259) - (253)(259)] \\ &= 512[(512)^2 - \{(512)^2 - 3(253)(259)\}] \\ &= (512)[3(253)(259)] \\ &= 2^9 \cdot 3 \cdot (253)(259) \\ &= 2^9 \cdot 3(11)(23)(7)(37) \end{aligned}$$

6 prime divisors.

11. Consider an incomplete pyramid of balls on a square base having 18 layers; and having 13 balls on each side of the top layer. Then the total number N of balls in that pyramid satisfies

(A) $9000 < N < 10000$ (B) $8000 < N < 9000$
 (C) $7000 < N < 8000$ (D) $10000 < N < 12000$

Ans. (B)

Sol. Top layer has (13×13) balls similarly are layer below top layer will have (14×14) balls

We have 18 layer

So total number of balls

$$N = (13)^2 + (14)^2 + \dots + (30)^2$$

$$N = \frac{30 \times 31 \times 61}{6} - \frac{12 \times 13 \times 25}{6}$$

$$N = 8805.$$

12. A man wants to reach a certain destination. One-sixth of the total distance is muddy while half the distance is tar road. For the remaining distance he takes a boat. His speed of traveling in mud, in water, on tar road is in the ratio $3 : 4 : 5$. The ratio of the durations he requires to cross the patch of mud, stream and tar road is

(A) $\frac{1}{2} : \frac{4}{3} : \frac{5}{2}$ (B) $3 : 8 : 15$ (C) $10 : 15 : 18$ (D) $1 : 2 : 3$

Ans. (C)

Sol. Let distance is $6x$

	mud	:	tar	:	stream
distance	x	:	$3x$:	$2x$
speed	$3v$:	$5v$:	$4v$
time	$\frac{x}{3v}$:	$\frac{3x}{5v}$:	$\frac{2x}{4v}$
	10	:	18	:	15

13. A frog is presently located at the origin $(0, 0)$ in the xy -plane. It always jumps from a point with integer coordinates to a point with integer coordinates moving a distance of 5 units in each jump. What is the minimum number of jumps required for the frog to go from $(0, 0)$ to $(0, 1)$?

(A) 2 (B) 3 (C) 4 (D) 9

Ans. (B)

Sol.

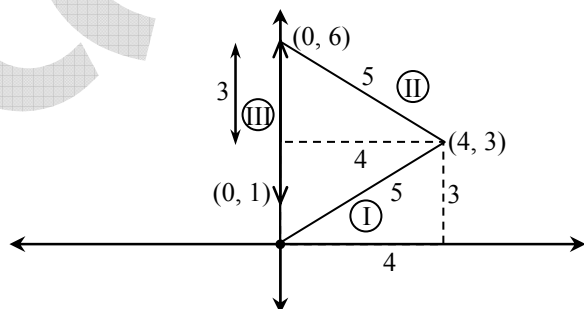

3 steps.



14. A certain 12-hour digital clock displays the hour and the minute of a day. Due to a defect in the clock whenever the digit 1 is supposed to be displayed it displays 7. What fraction of the day will the clock show the correct time ?

(A) $\frac{1}{2}$ (B) $\frac{5}{8}$ (C) $\frac{3}{4}$ (D) $\frac{5}{6}$

Ans. (A)

Sol. The clock will show the incorrect time (between 1 – 2, 10 -11, 11-12 , 12 - 1 day and night both)

\therefore in correct time $8 \times 60 = 480$ (each minute it will display 1)

Remaining 20 hours it will show the incorrect time $16 \times 15 = 240$

Total incorrect time = $240 + 480 = 720$

correct time = 1 – incorrect time

$$= 1 - \frac{720}{24 \times 60} = 1/2$$

15. There are 30 questions in a multiple –choice test. A student gets 1 mark for each unattempted question, 0 mark for each wrong answer and 4 marks for each correct answer. A student answered x question correctly and scored 60. Then the number of possible value of x is

(A) 15 (B) 10 (C) 6 (D) 5

Ans. (C)

Sol.

Right (4 marks)	Wrong (0 mark)	Unattempted (1 marks)
15	15	0
14		4
13		8
12		12
11		16
10		20

6 cases.

PHYSICS

16. A simple pendulum oscillates freely between points A and B.

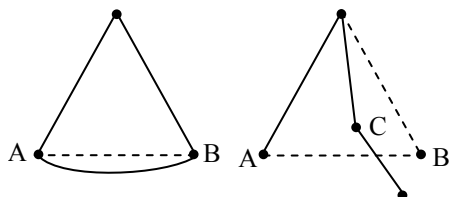

We now put a peg (nail) at some point C as shown. As the pendulum moves from A to the right, the string will bend at C and the pendulum will go to its extreme points D. Ignoring friction, the point D

- (A) will lie on the line AB
 (B) will lie above the line AB
 (C) will lie below the line AB
 (D) will coincide with B

Ans. (A)

Sol.

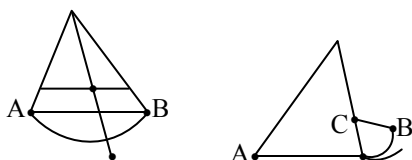

According to law of conservation of mechanical energy

$$K_i + U_i = K_f + U_f$$

$$0 + U_i = 0 + U_f$$

$$h_i = h_f$$

Point D is at line AB

17. A small child tries to move a large rubber toy placed on the ground. The toy does not move but gets deformed under her pushing force (\vec{F}) which is obliquely upward as shown. Then

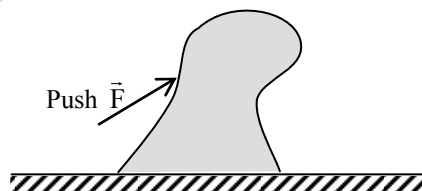

- (A) the resultant of the pushing force (\vec{F}), weight of the toy, normal force by the ground on the toy and the frictional force is zero
 (B) the normal force by the ground is equal and opposite to the weight of the toy
 (C) the pushing force (\vec{F}) of the child is balanced by the equal and opposite frictional force
 (D) the pushing force (\vec{F}) of the child is balanced by the total internal force in the toy generated due to deformation



Ans. (A)

Sol. $\because \sum F_{\text{ext.}} = 0$

$\therefore a_{\text{system}} = 0$

18. A juggler tosses a ball up in the air with initial speed u . At the instant it reaches its maximum height H , he tosses up a second ball with the same initial speed. The two balls will collide at a height

(A) $\frac{H}{4}$

(B) $\frac{H}{2}$

(C) $\frac{3H}{4}$

(D) $\sqrt{\frac{3}{4}}H$

Ans. (C)

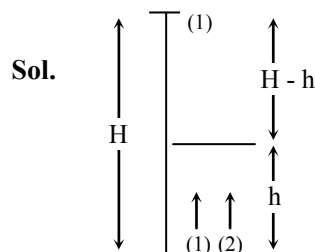

$$H - h = \frac{1}{2}gt^2$$

$$h = ut - \frac{1}{2}gt^2$$

$$H = ut \quad \dots(1)$$

$$\frac{u^2}{2g} = H \quad \dots(2)$$

$$t = \frac{u}{2g} \text{ (from (1) and (2))}$$

$$\begin{aligned} \therefore h &= u \times \frac{u}{2g} - \frac{1}{2}g \times \frac{u^2}{4g^2} \\ &= \frac{3u^2}{8g} = \frac{3H}{4} \end{aligned}$$

19. On a horizontal frictionless frozen lake, a girl (36 kg) and a box (9 kg) are connected to each other by means of a rope. Initially they are 20 m apart. The girl exerts a horizontal force on the box, pulling it towards her. How far has the girl traveled when she meets the box >

(A) 10 m

(B) Since there is no friction, the girl will not move

(C) 16 m

(D) 4m

Ans. (D)

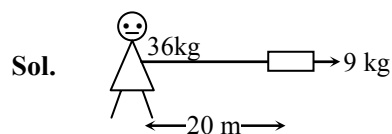

\therefore external force does not work on system

So according to concept of mass

$$36x = 9 \times (20 - x)$$

$$x = 4\text{m}$$

20. The following three objects (1) a metal tray, (2) a block of wood, and (3) a woolen cap are left in a closed room overnight. Next day the temperature of each is recorded as T_1 , T_2 and T_3 respectively. The likely situation is

(A) $T_1 = T_2 = T_3$ (B) $T_3 > T_2 > T_1$ (C) $T_3 = T_2 > T_1$ (D) $T_3 > T_2 = T_1$

Ans. (A)

Sol. All the three object will be in thermal equilibrium then % $T_1 = T_2 = T_3$.

21. We sit in the room with windows open. Then

(A) air pressure on the floor of the room equals the atmospheric pressure but the air pressure on the ceiling is negligible
 (B) air pressure is nearly the same on the floor, the walls and the ceiling
 (C) air pressure on the floor equals the weight of the air column inside the room (from floor to ceiling) per unit area
 (D) air pressure on the walls is zero since the weight of air acts downward

Ans. (B)

Sol. Pressure of gas is app. same everywhere in the vessel

22. A girl standing at point P on a beach wishes to reach a point Q in the sea as quickly as possible. She can run at 6 km h^{-1} on the beach and swim at 4 km h^{-1} in the sea. She should take the path

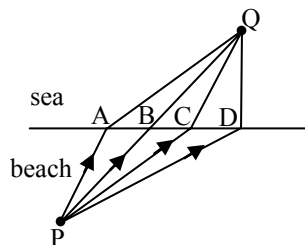

(A) PAQ (B) PBQ (C) PCQ (D) PDQ

Ans. (C)

Sol.

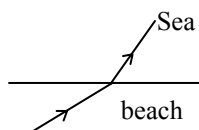

In beach velocity is higher

\therefore beach is rarer and sea is denser medium

So when it go from rarer to denser medium it bend toward normal to reach in minimum time.

23. Light enters an isosceles right triangular prism at normal incidence through face AB and undergoes total internal reflection at face BC as shown below.

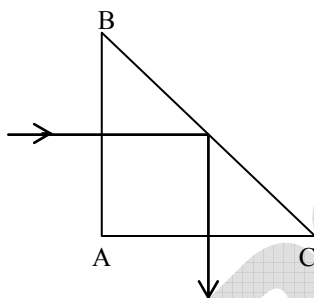

The minimum value of the refractive index of the prism is close to

- (A) 1.10 (B) 1.55 (C) 1.42 (D) 1.72

Ans. (C)

Sol. $i = 45^\circ \geq C$

For minimum refractive index $C = 45^\circ$

$$\mu \sin 45^\circ = 1$$

$$\mu = \sqrt{2} = 1.42$$

24. A convex lens is used to form an image of an object on a screen. If the upper half of the lens is blackened so that it becomes opaque, then

- (A) only half of the image will be visible (B) the image position shifts towards the lens
(C) the image position shifts away from the lens (D) the brightness of the image reduces

Ans. (D)

Sol.



Only half part of the lens will be used so its intensity will be decreased

25. A cylindrical copper rod has length L and resistance R. If it is melted and formed into another rod of length 2L, the resistance will be

- (A) R (B) 2R (C) 4R (D) 8R

Ans. (C)

Sol. Applying volume conservation

$$A \times L = A' \times 2L$$

$$A' = \frac{A}{2}$$

$$R = \frac{\rho L}{A}$$

$$R' = \frac{\rho \times 2L}{A'} = \frac{\rho \times 4L}{A}$$

$$R' = 4R$$

26. Two charges $+Q$ and $-2Q$ are located at points A and B on a horizontal line as shown below

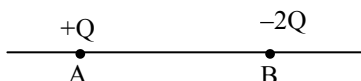

The electric field is zero at a point which is located at a finite distance

(A) on the perpendicular bisector of AB

(B) left of A on the line

(C) between A and B on the line

(D) right of B on the line

Ans. (B)

Sol.

27. A 750 W motor drives a pump which lifts 300 litres of water per minute to a height of 6 meters. The efficiency of the motor is nearly (take acceleration due to gravity to be 10 m/s^2)

(A) 30%

(B) 40%

(C) 50%

(D) 20%

Ans. (B)

Sol. $mgh = 300 \times 10 \times 6$

$$P_i = \frac{mgh}{t} = \frac{300 \times 10 \times 6}{60} = 300 \text{ W}$$

$$P_0 = 750 \text{ W}$$

$$\eta = \frac{300}{750} \times 100 = 40\%$$

28. Figure below shows a portion of an electric circuit with the currents in amperes and their directions. The magnitude and direction of the current in the portion PQ is

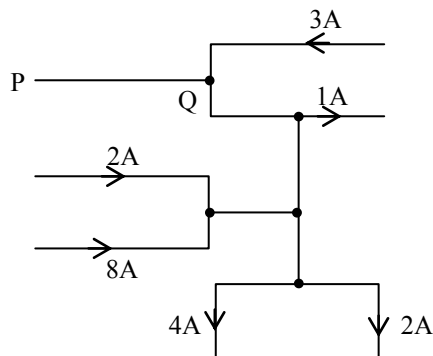

(A) 0A

(B) 3 A from P to Q

(C) 4 A from Q to P

(D) 6A from Q to P

Ans. (D)

Sol.

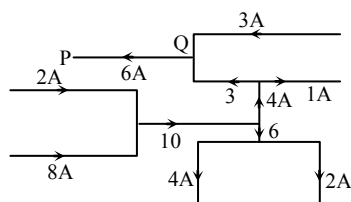

29. A nucleus of lead Pb_{82}^{214} emits two electrons followed by an alpha particle. The resulting nucleus will have
- (A) 82 protons and 128 neutrons (B) 80 protons and 130 neutrons
 (C) 82 protons and 130 neutrons (D) 78 protons and 134 neutrons

Ans. (A)

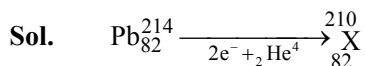
82 \rightarrow Proton

$$210 - 82 = 128 \text{ Neutron}$$

30. The number of air molecules in a $(5\text{m} \times 5\text{m} \times 4\text{m})$ room at standard temperature and pressure is of the order of
- (A) 6×10^{23} (B) 3×10^{24} (C) 3×10^{27} (D) 6×10^{30}

Ans. (C)

$$\text{Sol. } PV = N \times K \times T$$

where K is Boltzmann constant

$$10^5 \times 100 = N \times 1.38 \times 10^{-23} \times 273$$

$$N \approx 3 \times 10^{27}$$

CHEMISTRY

31. Two balloons A and B containing 0.2 mole and 0.1 mole of helium at room temperature and 2.0 atm, respectively, are connected. When equilibrium is established, the final pressure of He in the system is
- (A) 1.0 atm (B) 1.5 atm (C) 0.5 atm (D) 2.0 atm

Ans. (D)

Sol. Since pressure of the gases are same in both the containers. Therefore the final pressure will not change.

32. In the following set of aromatic compounds

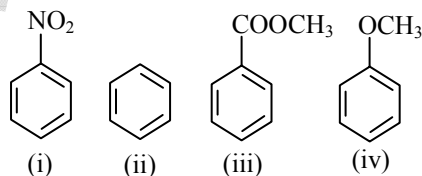

the correct order of reactivity toward Friedel-Crafts alkylation is

- (A) $i > ii > iii > iv$ (B) $ii > iv > iii > i$ (C) $iv > ii > iii > i$ (D) $iii > i > iv > ii$

Ans. (C)

Sol. $-\text{OCH}_3$ is activating group.

order of deactivating is $-\overset{\text{O}}{\parallel}{\text{C}}-\text{O}-\text{CH}_3 < -\text{NO}_2$

33. The set of principal (n), azimuthal (ℓ) and magnetic (m_1) quantum numbers that is not allowed for the electron in H-atom is

(A) $n = 3, \ell = 1, m_1 = -1$

(B) $n = 3, \ell = 0, m_1 = 0$

(C) $n = 2, \ell = 1, m_1 = 0$

(D) $n = 2, \ell = 2, m_1 = -1$

Ans. (D)

Sol. n is always greater than ℓ

and $m = -\ell, \dots, 0, \dots, +\ell$

If $n = 2$, then $\ell = 0, 1$

and $m_\ell = 0, \{-1, 0, +1\}$

34. At 298 K, assuming ideal behaviour, the average kinetic energy of a deuterium molecule is

(A) two times that of a hydrogen molecule

(B) four times that of a hydrogen molecule

(C) half of that of a hydrogen molecule

(D) same as that of a hydrogen molecule

Ans. (D)

Sol. $(\text{K.E.})_{\text{average}} = \frac{3}{2}kT$

i.e., average kinetic energy depends only on temperature.

35. As isolated box, equally partitioned contains two ideal gases A and B as shown

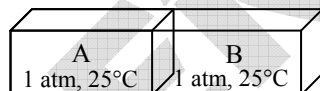

When the partition is removed, the gases mix. The changes in enthalpy (ΔH) and entropy (ΔS) in the process, respectively, are

(A) zero, positive

(B) zero, negative

(C) positive, zero

(D) negative, zero

Ans. (A)

Sol. According to KTG

Force of attraction and repulsion amongst molecules of ideal gas are negligible

So, $\Delta H = 0$

and randomness increases due to increase in volume so $\Delta S = +ve$.

36. The gas produced from thermal decomposition of $(\text{NH}_4)_2\text{Cr}_2\text{O}_7$ is

(A) oxygen

(B) nitric oxide

(C) ammonia

(D) nitrogen

Ans. (D)

Sol. $(\text{NH}_4)_2\text{Cr}_2\text{O}_7 \xrightarrow{\Delta} \text{N}_2 + \text{Cr}_2\text{O}_3 + 4\text{H}_2\text{O}$

37. The solubility curve of KNO_3 in water is shown below.

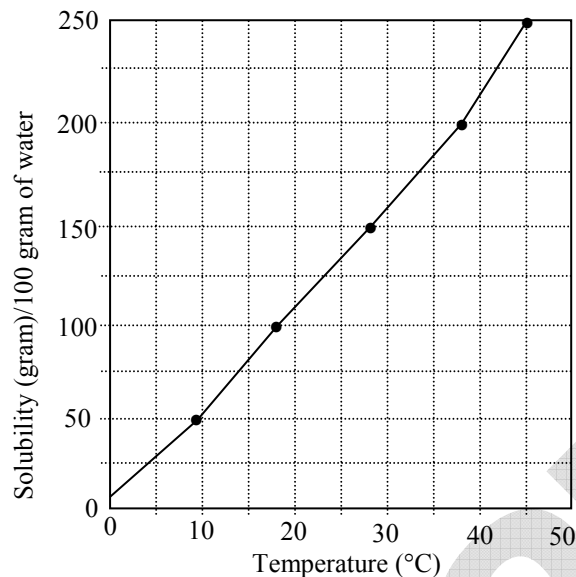

The amount of KNO_3 that dissolves in 50 g of water at 40°C is closest to

- (A) 100g (B) 150g (C) 200g (D) 50g

Ans. (A)

Sol. At 40°C solubility is 200 gm per 100 ml (approx)
 i.e., 100 ml of water contains = 200 gm of KNO_3 (approx)
 50 ml of water contains = 100 gm (approx)

38. A compound that shows positive iodoform test is

- (A) 2-pentanone (B) 3-pentanone (C) 3-pentanol (D) 1-pentanol

Ans. (A)

Sol. (A) $\text{CH}_3-\overset{\text{O}}{\parallel}{\text{C}}-\text{CH}_2-\text{CH}_2-\text{CH}_3$ Show iodoform test

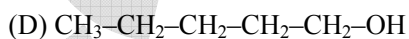

39. After 2 hours the amount of a certain radioactive substance reduces to $1/16^{\text{th}}$ of the original amount (the decay process follows first-order kinetics). The half-life of the radioactive substance is

- (A) 15 min (B) 30 min (C) 45 min (D) 60 min

Ans. (B)

Sol. $\frac{0.693}{t_{1/2}} = \frac{2.303}{2 \times 60} \log \frac{a}{a/16}$

$t_{1/2} = 30 \text{ min}$

40. In the conversion of zinc ore to zinc metal, the process of roasting involves

- (A) $\text{ZnCO}_3 \rightarrow \text{ZnO}$ (B) $\text{ZnO} \rightarrow \text{ZnSO}_4$ (C) $\text{ZnS} \rightarrow \text{ZnO}$ (D) $\text{ZnS} \rightarrow \text{ZnSO}_4$

Ans. (C)

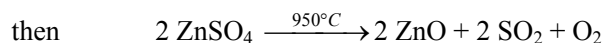
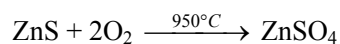
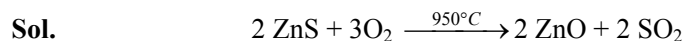

41. The number of P-H bond(s) in H_3PO_2 , H_3PO_3 and H_3PO_4 , respectively, is

- (A) 2, 0, 1 (B) 1, 1, 1 (C) 2, 0, 0 (D) 2, 1, 0

Ans. (D)

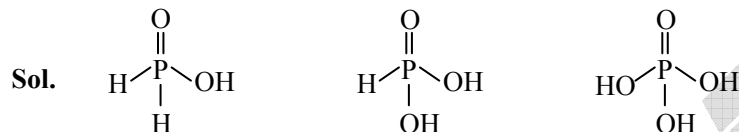

So, H_3PO_2 , H_3PO_3 and H_3PO_4 contains 2, 1 and zero P-H bonds.

42. When chlorine gas is passed through an aqueous solution of KBr, the solution turns orange brown due to the formation of

- (A) KCl (B) HCl (C) HBr (D) Br_2

Ans. (D)

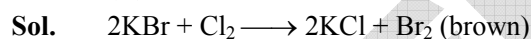

43. Among

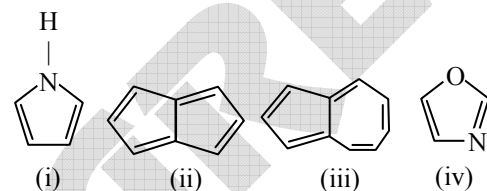

the compound which is not aromatic is

- (A) i (B) ii (C) iii (D) iv

Ans. (B)

Sol. (i) and (iv) are heteroaromatic compound.

(ii) is non aromatic.

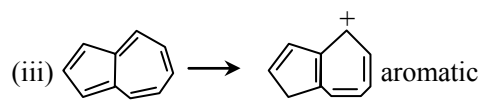

44. Among the following compounds

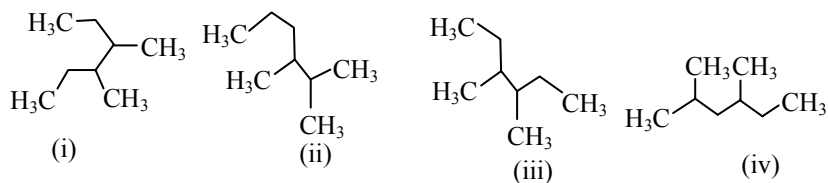

2, 3- dimethylhexane is

(A) i

(B) ii

(C) iii

(D) iv

Ans. (B)

Sol.

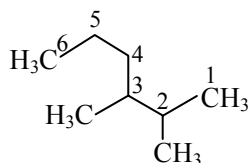

45. The major product formed in the reaction

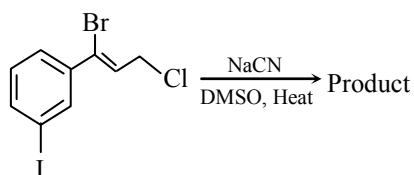

is

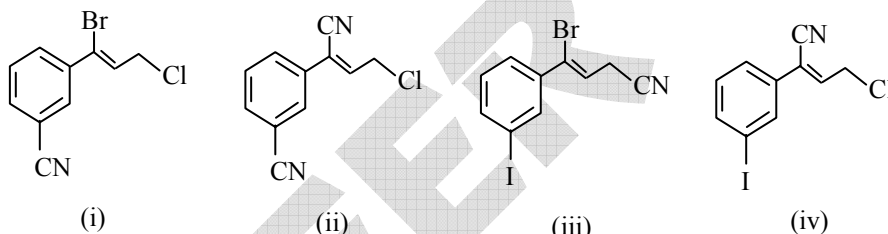

(A) i

(B) ii

(C) iii

(D) iv

Ans. (C)

Sol. Given reaction \rightarrow S_N2

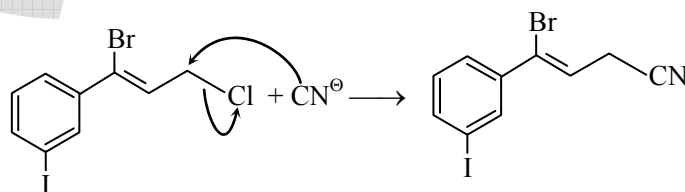

BIOLOGY

46. If parents have free ear lobes and the offspring has attached ear lobes, then the parents must be
(A) homozygous (B) heterozygous (C) co-dominant (D) nullizygous

Ans. (B)

47. During meiosis there is
(A) one round of DNA replication and one division (B) two rounds of DNA replication and one division
(C) two rounds of DNA replication and two division (D) one round of DNA replication and two division

Ans. (D)

Sol. DNA replication occur in S phase just before to meiosis-I only it will not replicates in between meiosis-I & meiosis-II

48. Blood clotting involves the conversion of
(A) prothrombin to thromboplastin (B) thromboplastin to prothrombin
(C) fibrinogen to fibrin (D) fibrin to fibrinogen

Ans. (C)

49. The gall bladder is involved in
(A) synthesizing bile (B) storing and secreting bile
(C) degrading bile (D) producing insulin

Ans. (B)

50. Which one of the following colours is the LEAST useful for plant life?
(A) red (B) blue (C) green (D) violet

Ans. (C)

51. At rest the volume of air that moves in and out per breath is called
(A) resting volume (B) vital capacity
(C) lung capacity (D) tidal volume

Ans. (D)

52. How many sex chromosomes does a normal human inherit from father?
(A) 1 (B) 2 (C) 23 (D) 46

Ans. (A)

Sol. Either X or Y chromosome



53. In the 16th century, sailors who travelled long distances had diseases related to malnutrition, because they were not able to eat fresh vegetables and fruits for months at a time. Scurvy is a result of deficiency of
(A) carbohydrates (B) proteins (C) Vitamin C (D) Vitamin D
Ans. (C)
54. The following structure is NOT found in plant cells
(A) vacuole (B) nucleus
(C) centriole (D) endoplasmic reticulum
Ans. (C)
Sol. Centriole or centrosome is only present in animal
55. The cell that transfers information about pain to the brain is called a
(A) neuron (B) blastocyst (C) histoblast (D) haemocyte
Ans. (A)
56. The presence of nutrients in the food can be tested. Benedict's test is used to detect
(A) sucrose (B) glucose (C) fatty acid (D) vitamin
Ans. (B)
Sol. Only reducing sugar give the test with benedict solution.
57. Several minerals such as iron, iodine, calcium and phosphorous are important nutrients. Iodine is found in
(A) thyroxine (B) adrenaline (C) insulin (D) testosterone
Ans. (A)
58. The principle upon which a lactometer works is
(A) viscosity (B) density
(C) surface tension (D) presence of protein
Ans. (B)
59. Mammalian liver cells will swell when kept in
(A) hypertonic solution (B) hypotonic solution
(C) isotonic solution (D) isothermal solution
Ans. (B)
Sol. Endo-osmosis occur in cell, when cell is placed in Hypotonic solution
60. The form of cancer called 'carcinoma' is associated with
(A) lymph cells (B) mesodermal cells (C) blood cells (D) epithelial cells
Ans. (D)



PART -II
Two-Mark Question
MATHEMATICS

61. Let $f(x) = ax^2 + bx + c$, where a, b, c are integers. Suppose $f(1) = 0$, $40 < f(6) < 50$, $60 < f(7) < 70$, and $1000t < f(50) < 1000(t+1)$ for some integer t . Then the value of t is
- (A) 2 (B) 3 (C) 4 (D) 5 or more

Ans. (C)

Sol. $f(x) = ax^2 + bx + c$
given $f(1) = 0$
 $\Rightarrow a + b + c = 0$
and $40 < f(6) < 50$
 $\Rightarrow 40 < 36a + 6b + c < 50$
 $\Rightarrow 40 < 35a + 5b < 50$
 $\Rightarrow 8 < 7a + b < 10$
 $7a + b = \text{integer} = 9 \quad \dots(1)$
and $60 < f(7) < 70$
 $\Rightarrow 60 < 49a + 7b + c < 70$
 $\Rightarrow 60 < 48a + 6b < 70$
 $\Rightarrow 10 < 8a + b < 11.6$
 $8a + b = \text{integer} = 11 \quad \dots(2)$
Solving (1) & (2)
 $a = 2, b = -5, c = 3$
 $\therefore f(x) = 2x^2 - 5x + 3$
 $f(50) = 4753$
 $1000t < f(50) < 1000(t+1)$
 $(1000 \times 4) < 4753 < 1000(4+1)$
 $\therefore t = 4$

62. The expression $\frac{2^2+1}{2^2-1} + \frac{3^2+1}{3^2-1} + \frac{4^2+1}{4^2-1} + \dots + \frac{(2011)^2+1}{(2011)^2-1}$ lies in the interval

- (A) $\left(2010, 2010\frac{1}{2}\right)$ (B) $\left(2011 - \frac{1}{2011}, 2011 - \frac{1}{2012}\right)$
(C) $\left(2011, 2011\frac{1}{2}\right)$ (D) $\left(2012, 2012\frac{1}{2}\right)$

Ans. (C)

Sol. $\frac{2^2+1}{2^2-1} + \frac{3^2+1}{3^2-1} + \frac{4^2+1}{4^2-1} + \dots + \frac{(2011)^2+1}{(2011)^2-1}$
$$\sum_{r=2}^{2011} \frac{r^2+1}{r^2-1} = \sum_{r=2}^{2011} \left[1 + \frac{2}{(r+1)(r-1)}\right]$$



$$\begin{aligned}
 &= \sum_{r=2}^{2011} \left[1 + \frac{1}{r-1} - \frac{1}{r+1} \right] \\
 &= 2010 + \left[1 - \frac{1}{3} + \frac{1}{2} - \frac{1}{4} + \frac{1}{3} - \frac{1}{5} + \dots + \frac{1}{2010} - \frac{1}{2012} \right] \\
 &= 2010 + 1 + \frac{1}{2} - \frac{1}{2012} - \frac{1}{2011} \\
 &= 2011 + \frac{1}{2} - \left[\frac{1}{2011} + \frac{1}{2012} \right]
 \end{aligned}$$

lies between $\left(2011, 2011\frac{1}{2} \right)$

63. The diameter of one of the bases of a truncated cone is 100 mm. If the diameter of this base is increased by 21% such that it still remains a truncated cone with the height and the other base unchanged, the volume also increases by 21%. The radius of the other base (in mm) is-
- (A) 65 (B) 55 (C) 45 (D) 35

Ans. (B)

Sol. Let initially 2 bases have radii 5 cm and r cm.
Finally base have radii (1.21×5) and r

$$\text{Ratios of volumes} = \frac{V_2}{V_1} = 1.21$$

$$V_2 = \frac{\pi h}{3} [(6.05)^2 + (6.05)r + r^2]$$

$$V_1 = \frac{\pi h}{3} [5^2 + 5r + r^2]$$

$$\frac{V_2}{V_1} = 1.21 \Rightarrow \frac{(6.05)^2 + (6.05)r + r^2}{5^2 + 5r + r^2} = 1.21$$

$$\Rightarrow r^2 = \frac{6.3525}{21}$$

$$\Rightarrow r = \frac{11}{2} \text{ cm} = 55 \text{ mm}$$

64. Two friends A and B are 30 km apart and they start simultaneously on motorcycles to meet each other. The speed of A is 3 times that of B. The distance between them decreases at the rate of 2 km per minute. Ten minutes after they start, A's vehicle breaks down and A stops and waits for B to arrive. After how much time (in minutes) A started riding, does B meet A?
- (A) 15 (B) 20 (C) 25 (D) 30

Ans. (D)

Sol. Speed of B = V km/hr

Speed of A = 3V km/hr

Given $4V = 2 \times 60$ km/hr

$$\Rightarrow V = 30 \text{ km/hr}$$

Distance covered by then after 10 min = $2 \times 10 = 20 \text{ km}$

so remaining distance = $(30 - 20) \text{ km} = 10 \text{ km}$

$$\text{Time taken by B to cover 10 km} = \frac{10}{30/60} = 20 \text{ min.}$$

$$\text{Total time} = 20 + 10 = 30 \text{ min}$$

65. Three taps A, B, C fill up a tank independently in 10 hr, 20 hr, 30 hr, respectively. Initially the tank is empty and exactly one pair of taps is open during each hour and every pair of taps is open at least for one hour.

What is the minimum number of hours required to fill the tank?

- (A) 8 (B) 9 (C) 10 (D) 11

Ans. (A)

Sol. A 10 hr
B 20 hr
C 30 hr

Exactly one pair of taps is open during each hour and every pair of taps is open at least for one hour.

First A and B are open for 1 hour then B and C and then C and A

$$\left(\frac{1}{10} + \frac{1}{20}\right) + \left(\frac{1}{20} + \frac{1}{30}\right) + \left(\frac{1}{30} + \frac{1}{10}\right) = \frac{22}{60}$$

first second third

In three hours the tank will be filled $\left(\frac{22}{60}\right)^{\text{th}}$ part.

Now, for minimum time the rest tank must be filled with A and B taps

$$\left(\frac{1}{10} + \frac{1}{20} = \frac{9}{60}\right)$$

So the rest $\left(\frac{38}{60}\right)^{\text{th}}$ part of tank will take 5 hours more.

So the tank will be filled in 8th hour.

PHYSICS

66. An object with uniform density ρ is attached to a spring that is known to stretch linearly with applied force as shown below.

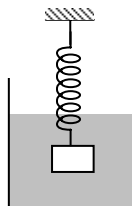

When the spring-object system is immersed in a liquid of density ρ_1 as shown in the figure, the spring stretches by an amount x_1 ($\rho > \rho_1$). When the experiment is repeated in a liquid of density $\rho_2 < \rho_1$, the spring stretches by an amount x_2 . Neglecting any buoyant force on the spring, the density of the object is

(A) $\rho = \frac{\rho_1 x_1 - \rho_2 x_2}{x_1 - x_2}$

(B) $\rho = \frac{\rho_1 x_2 - \rho_2 x_1}{x_2 - x_1}$

(C) $\rho = \frac{\rho_1 x_2 + \rho_2 x_1}{x_1 + x_2}$

(D) $\rho = \frac{\rho_1 x_1 + \rho_2 x_2}{x_1 + x_2}$

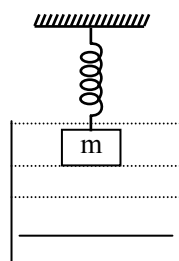
Ans. (B)**Sol.**

F.B.D.

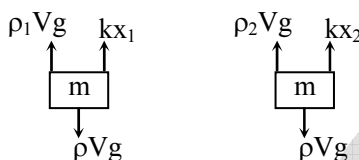

$$kx_1 + \rho_1 Vg = \rho Vg \quad \dots(1)$$

$$kx_2 + \rho_2 Vg = \rho Vg \quad \dots(2)$$

from (1) and (2)

$$\rho = \frac{\rho_2 x_1 - \rho_1 x_2}{x_1 - x_2} = \frac{\rho_1 x_2 - \rho_2 x_1}{x_2 - x_1}$$

67. A body of 0.5 kg moves along the positive x-axis under the influence of a varying force F (in Newtons) as shown below.

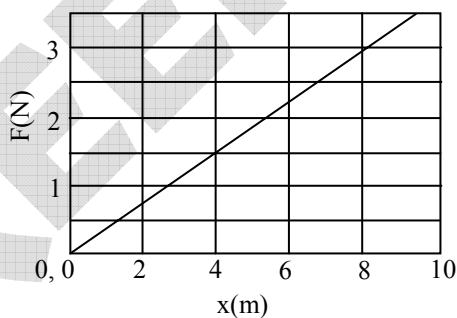

If the speed of the object at $x = 4\text{ m}$ is 3.16 ms^{-1} then its speed at $x = 8\text{ m}$ is

(A) 3.16 ms^{-1}

(B) 9.3 ms^{-1}

(C) 8 ms^{-1}

(D) 6.8 ms^{-1}

Ans. (D)**Sol.** According to work-energy principle

$$W_C + W_{nc} + W_{ext} = \Delta KE$$

$$\int_4^8 F dx = \frac{1}{2} m v_f^2 - \frac{1}{2} m v_i^2$$

$$\frac{1}{2} \times 3 \times 8 - \frac{1}{2} \times 1.5 \times 4 = \frac{1}{2} \times \frac{1}{2} [v_f^2 - (3.16)^2]$$

$$v_f = 6.8 \text{ m/s}$$

68. In a thermally isolated system, two boxes filled with an ideal gas are connected by a valve. When the valve is in closed position, states of the box 1 and 2, respectively, are (1 atm, V, T) and (0.5 atm, 4V, T). When the valve is opened, the final pressure of the system is approximately
- (A) 0.5 atm (B) 0.6 atm (C) 0.75 atm (D) 1.0 atm

Ans. (B)

Sol.

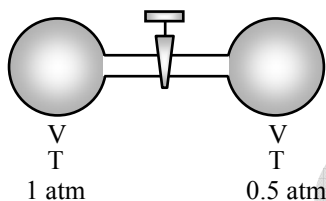

After opening of at equilibrium temperature and pressure of whole gas is T_1 and P_1

$$n_1 = \frac{1 \times V}{RT}, \quad n_2 = \frac{0.5 \times V \times 4}{RT}$$

$$n_1 + n_2 = n$$

$$\frac{V}{RT} + \frac{V \times 4}{2RT} = \frac{5VP_1}{RT_1}$$

$$\frac{3V}{RT} = \frac{5VP_1}{RT_1}$$

$$\frac{P_1}{T_1} = \frac{0.6}{T}$$

$$\Delta Q = 0, \quad \Delta W = 0$$

$$\therefore \Delta U = 0$$

$$n_1 C_V T + n_2 C_V T = (n_1 + n_2) C_V T_1$$

$$T_1 = T$$

$$\frac{P_1}{T} = \frac{0.6}{T}$$

$$P_1 = 0.6 \text{ atm}$$

69. A student sees the top edge and the bottom center C of a pool simultaneously from an angle θ above the horizontal as shown in the figure. The refraction index of water which fills up to the top edge of the pool is $4/3$. If $h/x = 7/4$ then $\cos \theta$ is

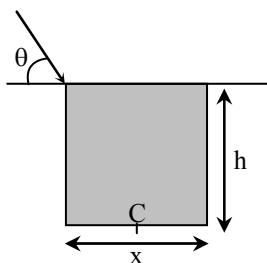

(A) $\frac{2}{7}$

(B) $\frac{8}{3\sqrt{45}}$

(C) $\frac{8}{3\sqrt{53}}$

(D) $\frac{8}{21}$

Ans. (C)

Sol.

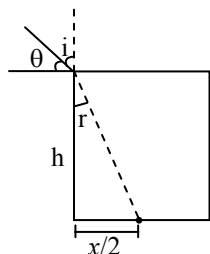

$$1 \times \sin i = \mu \sin r$$

$$\sin (90 - \theta) = \frac{4}{3} \sin r$$

$$\tan r = \frac{x}{2h} = \frac{4}{7 \times 2} = \frac{2}{7}$$

$$\sin r = \frac{2}{\sqrt{53}}$$

$$\cos \theta = \frac{4}{3} \times \frac{2}{\sqrt{53}} = \frac{8}{3\sqrt{53}}$$

70. In the following circuit, the 1Ω resistor dissipates power P. If the resistor is replaced by 9Ω , the power dissipated in it is

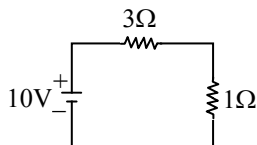

(A) P

(B) 3P

(C) 9P

(D) P/3

Ans. (A)

Sol.

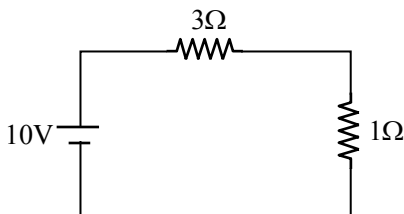

$$10 = 4i$$

$$i = \frac{5}{2}$$

$$P_i = i^2 R = \left(\frac{5}{2}\right)^2 \times 1 = \frac{25}{4}$$

$$P_f = \left(\frac{10}{12}\right)^2 \times 9 = \frac{100}{12 \times 12} \times 9$$

$$P_f = P_i$$

CHEMISTRY

71. An aqueous buffer is prepared by adding 100 ml of 0.1 mol l^{-1} acetic acid to 50 ml of 0.2 mol l^{-1} of sodium acetate. If pK_a of acetic acid is 4.76, the pH of the buffer is

(A) 4.26 (B) 5.76 (C) 3.76 (D) 4.76

Ans. (D)

Sol. Meq of $\text{CH}_3\text{COOH} = 100 \times 0.1 \times 1 = 10$

Meq of $\text{CH}_3\text{COONa} = 50 \times 0.2 \times 1 = 10$

$$\text{pH} = \text{pK}_a + \log \frac{[\text{CH}_3\text{COO}^-]}{[\text{CH}_3\text{COOH}]}$$

$$\text{pH} = 4.76 + \log \frac{10}{10}$$

$$\text{pH} = 4.76 + \log 1$$

$$\text{pH} = 4.76$$

72. The maximum number of structural isomers possible for the hydrocarbon having the molecular formula C_4H_6 , is

(A) 12 (B) 3 (C) 9 (D) 5

Ans. (C)

Sol. Possible structural isomers are nine.

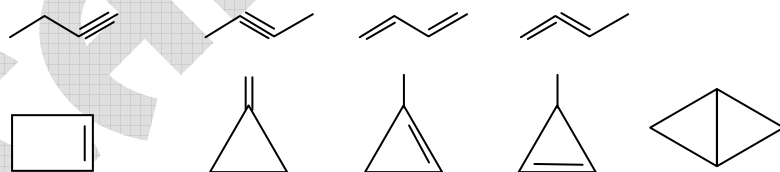

73. In the following reaction sequence, X and Y, respectively are



(A) H_2O_2 ; LiAlH_4 (B) $\text{C}_6\text{H}_5\text{COOOH}$; LiAlH_4 (C) $\text{C}_6\text{H}_5\text{COOOH}$; Zn/Hg.HCl (D) Alkaline KMnO_4 ; LiAlH_4

Ans. (B)

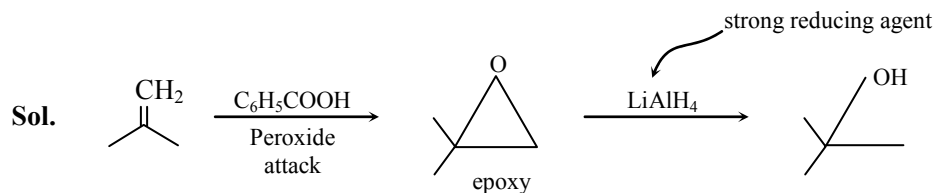

74. Among (i) $[\text{Co}(\text{NH}_3)_6]\text{Cl}_3$, (ii) $[\text{Ni}(\text{NH}_3)_6]\text{Cl}_2$, (iii) $[\text{Cr}(\text{H}_2\text{O})_6]\text{Cl}_3$, (iv) $[\text{Fe}(\text{H}_2\text{O})_6]\text{Cl}_2$ the complex which is diamagnetic is

(A) i

(B) ii

(C) iii

(D) iv

Ans. (A)

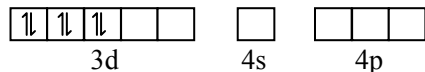
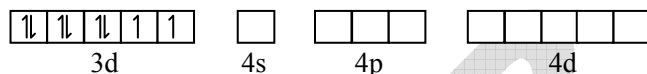
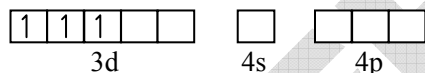
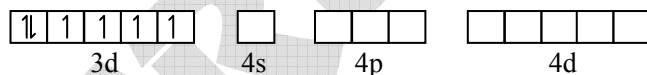
Sol. (i) $\text{Co}^{+3} = [\text{Ar}] 3d^6 4s^0$ NH_3 is a strong field ligand(ii) $\text{Ni}^{+2} = [\text{Ar}] 3d^8 4s^0$ NH_3 is a strong field ligand(iii) $\text{Cr}^{+3} = [\text{Ar}] 3d^3 4s^0$ H_2O is a weak field ligand(iv) $\text{Fe}^{+2} = [\text{Ar}] 3d^6 4s^0$ H_2O is a weak field ligand.So, $[\text{Co}(\text{NH}_3)_6]\text{Cl}_3$ will be diamagnetic.

75. At 783 K in the reaction $\text{H}_2(\text{g}) + \text{I}_2(\text{g}) \rightleftharpoons 2\text{HI}(\text{g})$, the molar concentrations (mol^{-1}) of H_2 , I_2 and HI at some instant of time are 0.1, 0.2 and 0.4, respectively. If the equilibrium constant is 46 at the same temperature, then as the reaction proceeds

(A) the amount of HI will increase(B) the amount of HI will decrease(C) the amount of H_2 and I_2 will increase(D) the amount of H_2 and I_2 will not change

Ans. (A)

Sol. Reaction quotient



$$Q = \frac{[HI]^2}{[H_2][I_2]} = \frac{0.4 \times 0.4}{0.1 \times 0.2}$$

$$Q = 8$$

$$Q < K$$

So reaction will proceed in forward direction.

Hence amount of HI increases.

BIOLOGY

76. You remove four fresh tobacco leaves of similar size and age. Leave "leaf 1" as it is, smear "leaf 2" with vaseline on the upper surface, "leaf 3" on the lower surface and "leaf 4" on both the surfaces. Hang the leaves for a few hours and you observe that leaf 1 wilts the most, leaf 2 has wilted, leaf 3 wilted less than leaf 2 and leaf 4 remains fresh. Which of the following conclusion is most logical ?

- (A) tobacco leaf has more stomata on the upper surface
- (B) tobacco leaf has more stomata on the lower surface
- (C) stomata are equally distributed in upper and lower surfaces
- (D) no conclusion on stomatal distribution can be drawn from this experiment

Ans. (B)

77. Vestigial organs such as the appendix exist because

- (A) they had an important function during development which is not needed in the adult
- (B) they have a redundant role to play if an organ with similar function fails
- (C) nature cannot get rid of structures that have already formed
- (D) they were inherited from an evolutionary ancestor in which they were functional

Ans. (D)

78. Mendel showed that unit factors, now called alleles, exhibit a dominant/ recessive relationship. In a monohybrid cross, the trait disappears in the first filial generation

- (A) dominant
- (B) co-dominant
- (C) recessive
- (D) semi-dominant

Ans. (C)

Sol. Recessive allele does not express itself in presence of dominant allele.

79. If a man with an X-linked dominant disease has six sons with a woman having a normal complement of genes, then the sons will

- (A) not show any symptoms of the disease
- (B) show strong symptoms of the disease
- (C) three will show a disease symptom, while three will not
- (D) five will show a disease symptom, while one will not

Ans. (A)



Sol. Son get their X chromosome from mother.

- 80.** In evolutionary terms, an Indian school boys is more closely related to
(A) an Indian frog (B) an American snake
(C) a Chinese horse (D) an African shark

Ans. (C)

Sol. Human & horse both belongs to mammalia .

CAREER POINT